

# OIL PUMP COMPONENTS

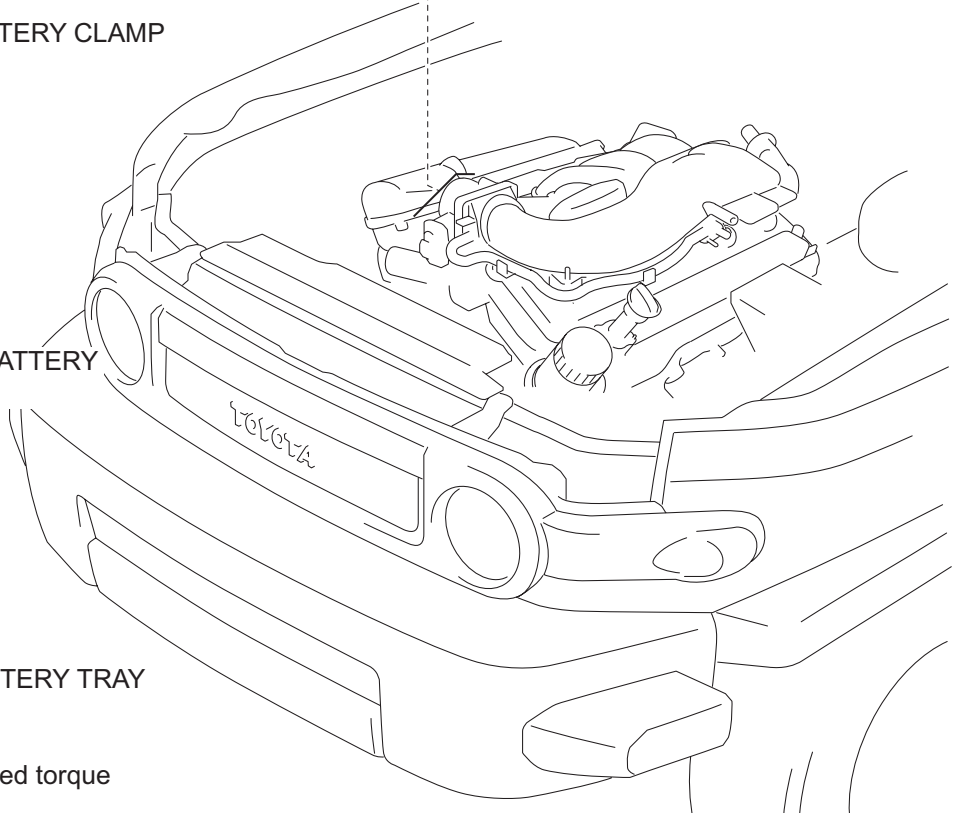

**N\*m (kgf\*cm, ft\*lbf)** : Specified torque

LU

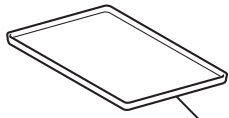
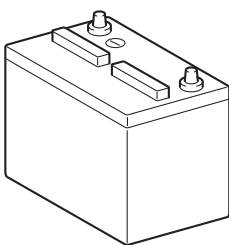
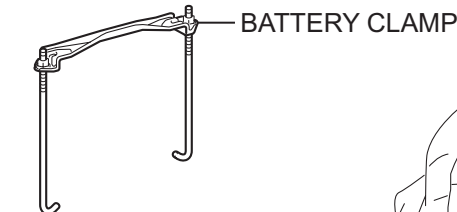
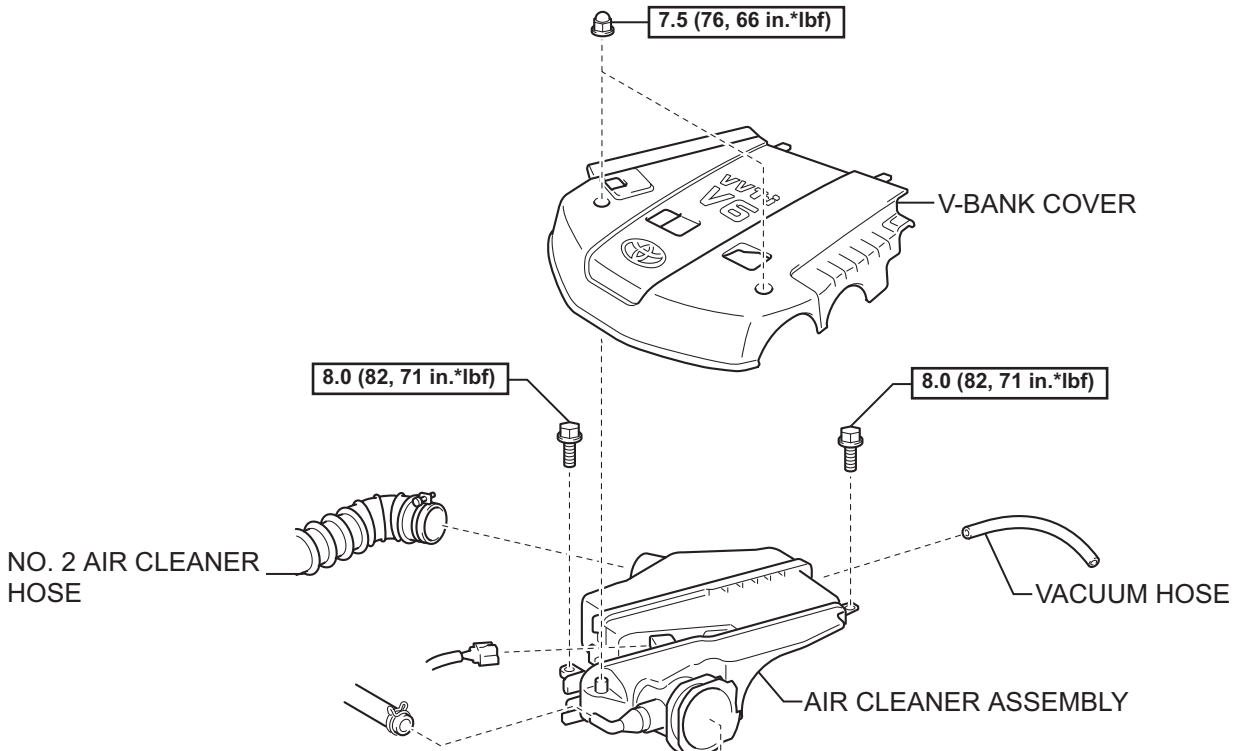
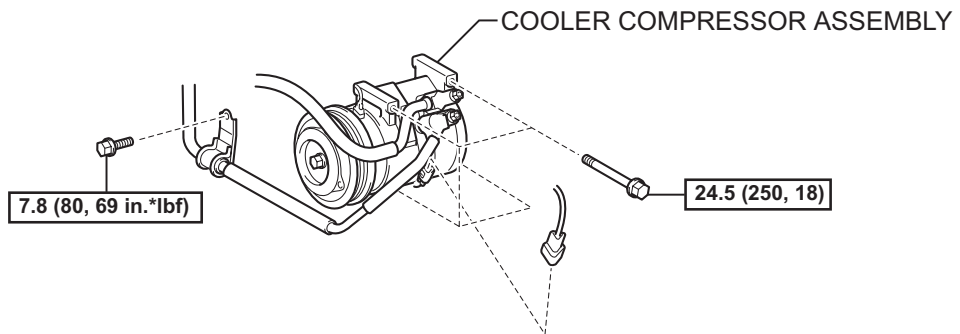
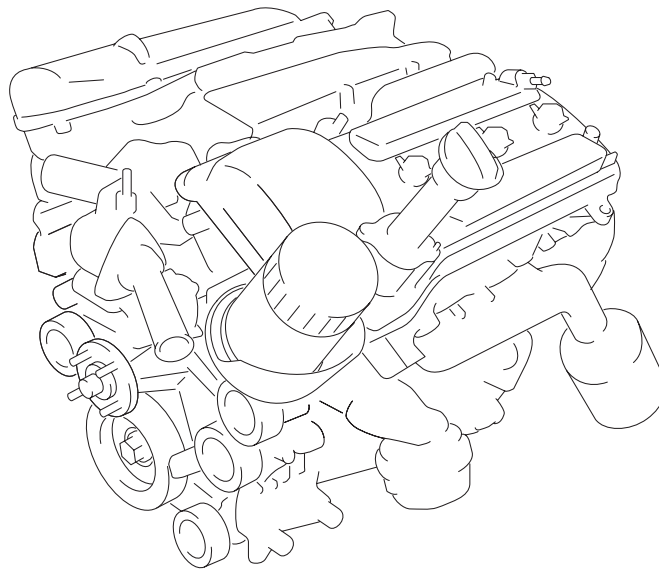
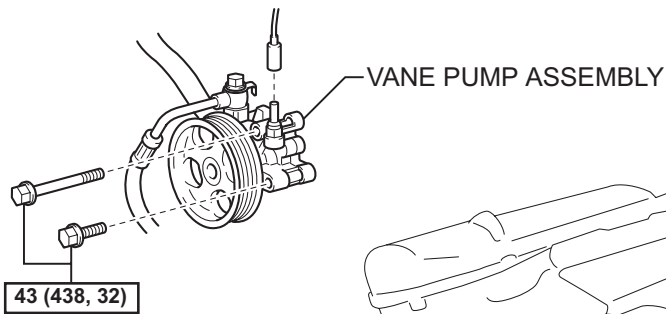
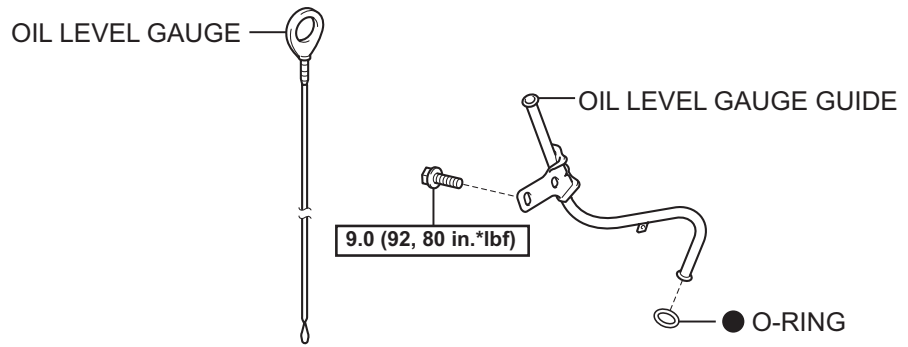

**N\*m (kgf\*cm, ft\*lbf)** : Specified torque

● Non-reusable part

LU

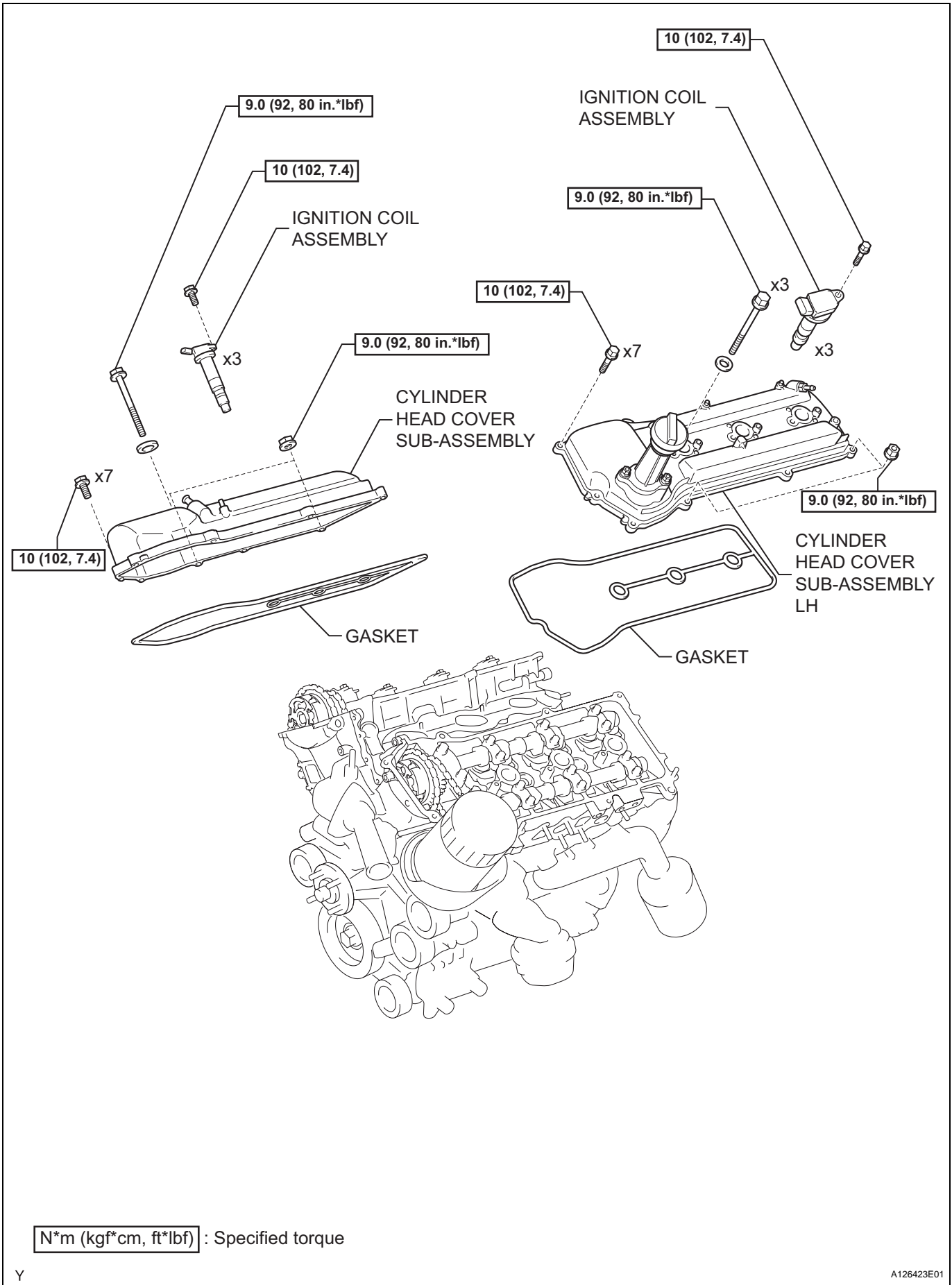

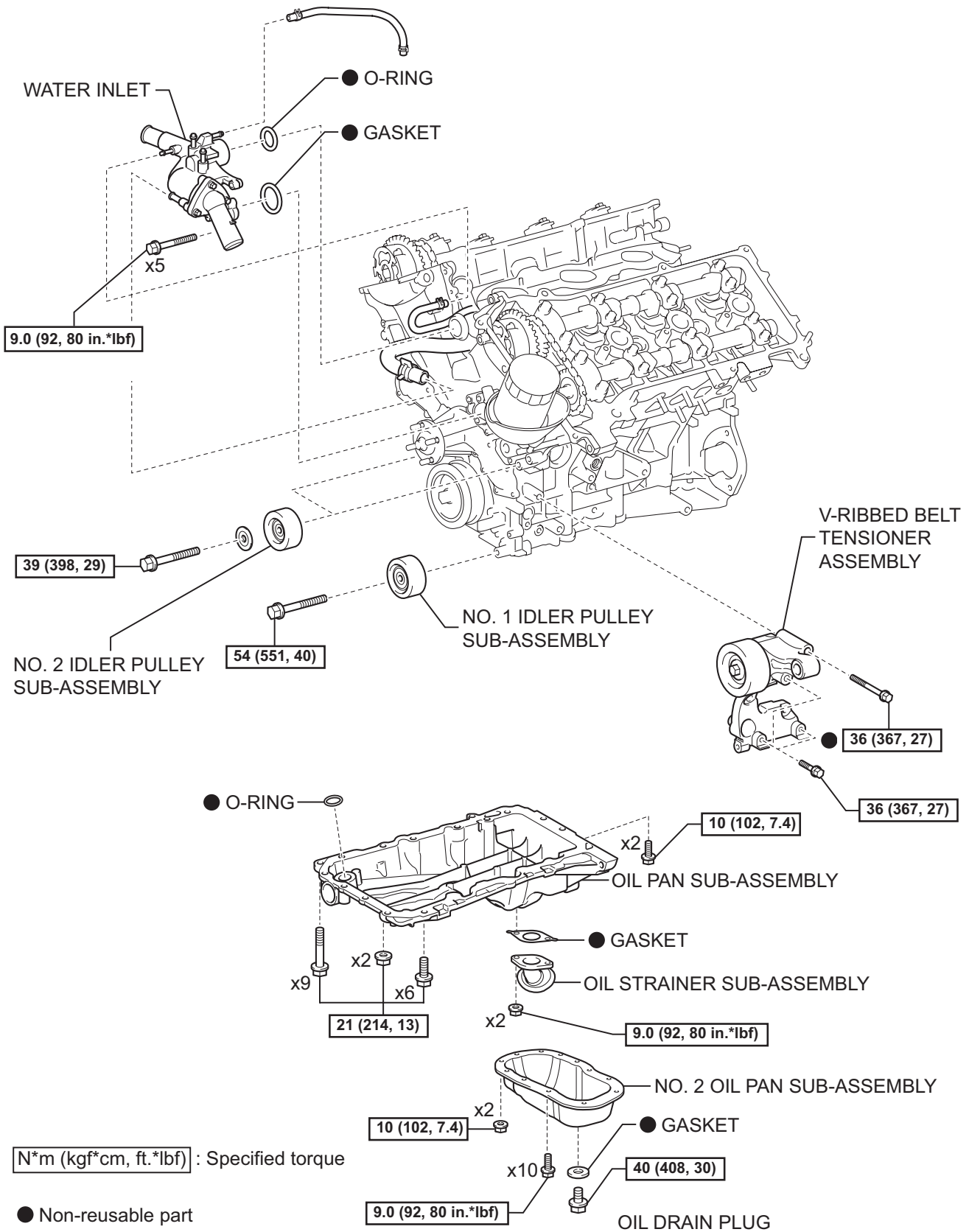

LU

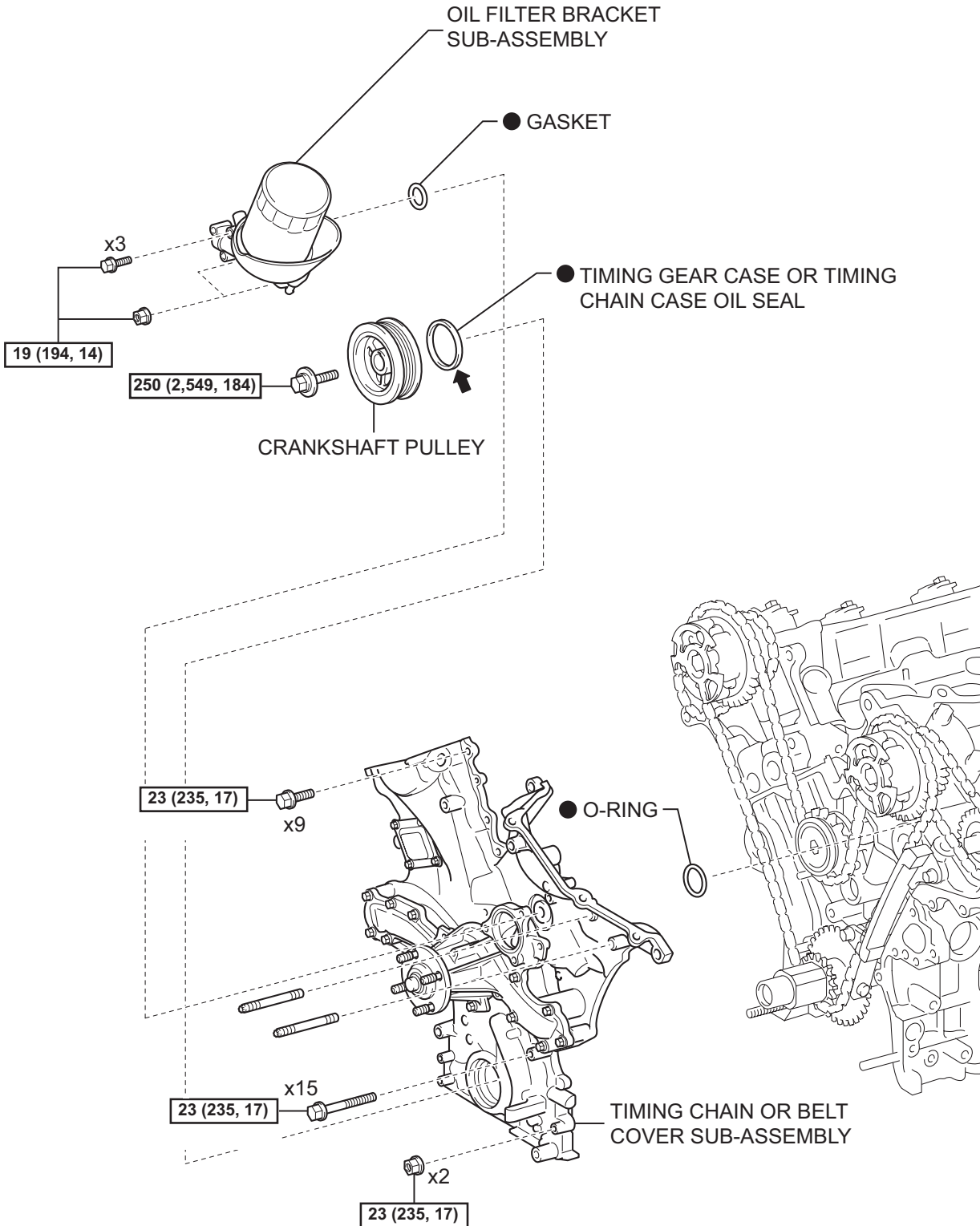

**N\*m (kgf\*cm, ft\*lbf)** : Specified torque

● Non-reusable part

➡ Apply MP grease

LU

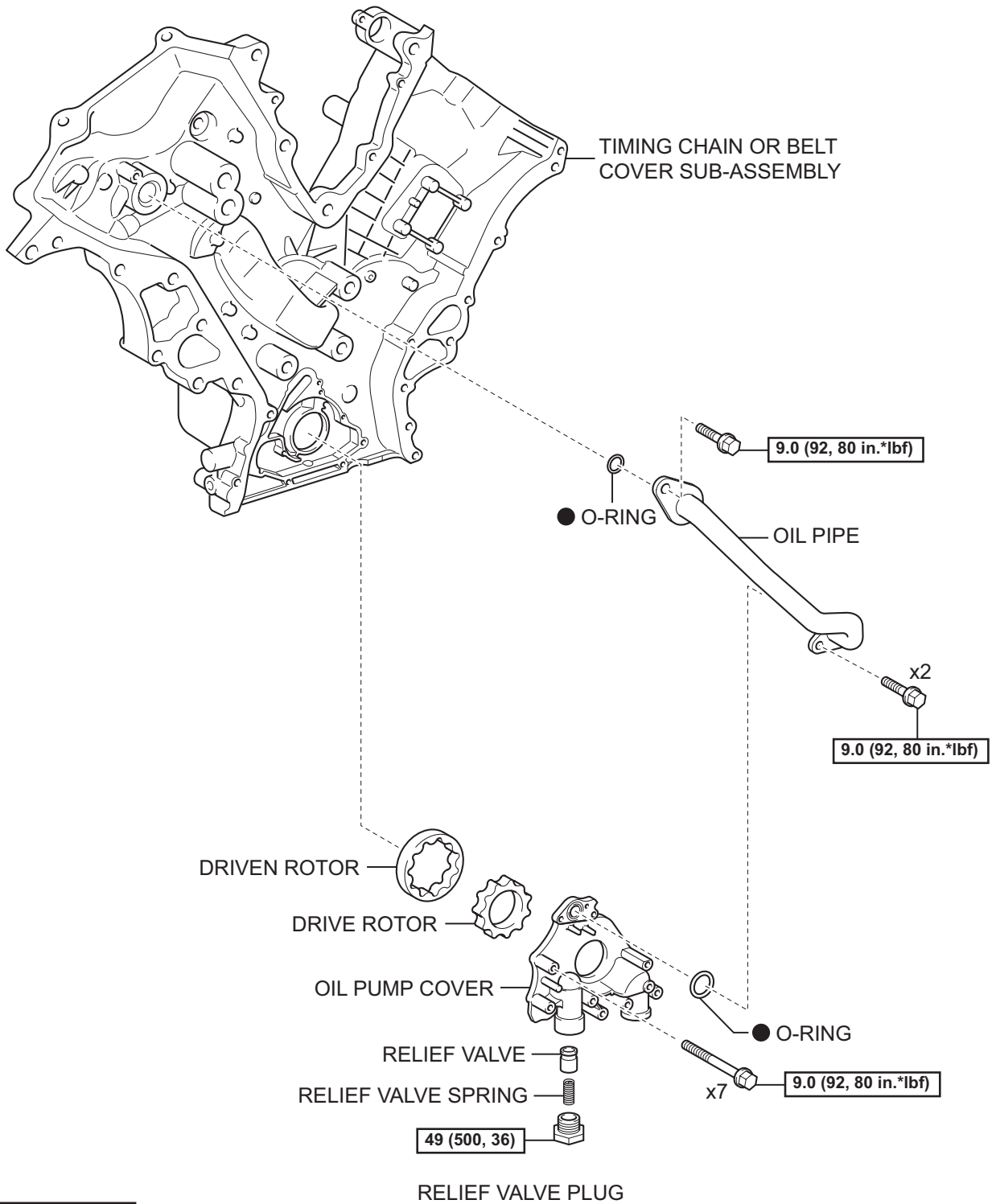

LU

**N\*m (kgf\*cm, ft\*lbf)** : Specified torque

● Non-reusable part